

Instruction Manual

HI 9835

Autoranging Portable Waterproof Microprocessor EC/TDS/NaCl/°C Meter

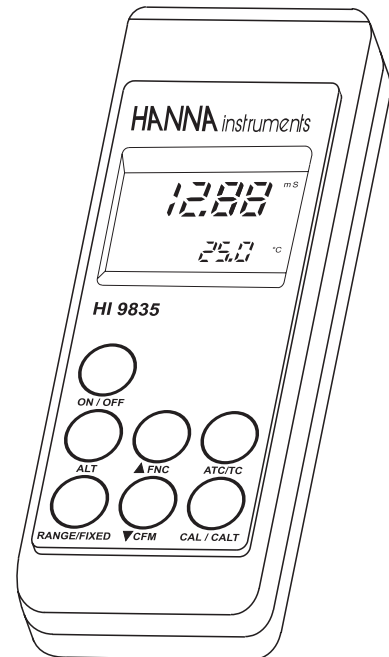

 **HANNA**
instruments
Manufacturers since 1978

This Instrument is in
Compliance with the CE Directives

Dear Customer,

Thank you for choosing a Hanna product.

Please read this instruction manual carefully before using the instrument.

This manual will provide you with the necessary information for a correct use of the instrument, as well as a precise idea of its versatility. If you need additional technical information, do not hesitate to e-mail us at tech@hannainst.com.

These instruments are in compliance with **CE** directives EN 50081-1, EN 50082-1 and EN 61010-1.

TABLE OF CONTENTS

PRELIMINARY EXAMINATION	3
GENERAL DESCRIPTION	3
FUNCTIONAL DESCRIPTION	4
SPECIFICATIONS	5
CONNECTIONS	6
TAKING MEASUREMENTS	7
AUTORANGING	8
TEMPERATURE COMPENSATION	8
EC / TDS CALIBRATION	9
NaCl CALIBRATION	10
TEMPERATURE CALIBRATION	11
TEMPERATURE ADJUSTMENT	11
CONDUCTIVITY VS. TEMPERATURE CHART	12
SETUP	13
BATTERY REPLACEMENT	15
PROBE MAINTENANCE	15
ACCESSORIES	16
WARRANTY	18
CE DECLARATION OF CONFORMITY	19

All rights are reserved. Reproduction in whole or in part is prohibited without the written consent of the copyright owner, Hanna Instruments Inc., 584 Park East Drive, Woonsocket, Rhode Island, 02895, USA.

Visit our Internet Home Page:
<http://www.hannainst.com>

PRELIMINARY EXAMINATION

Remove the instrument from the packing material and examine it carefully to make sure that no damage has occurred during shipping. If there is any damage, notify your Dealer.

Each meter is supplied complete with:

- HI76309 Conductivity/TDS probe
- AA size Alkaline Batteries (4 pcs)
- Instruction manual
- Rugged Carrying Case.

Note: Save all packing material until you are sure that the instrument functions correctly. Any defective item must be returned in its original packaging together with the supplied accessories.

GENERAL DESCRIPTION

HI 9835 is a waterproof portable microprocessor-based Conductivity/TDS/NaCl/temperature meter.

The autoranging feature of the EC and TDS ranges automatically sets the meter to the scale with the highest possible resolution.

The measurements are automatically (ATC) or manually (MTC) compensated for temperature. The temperature coefficient value is user selectable. It is possible to disable the temperature compensation and measure the actual conductivity.

The meter is equipped with a stability indicator.

The Battery Error Preventing System (BEPS) switches the meter off when the batteries are too weak to support proper function.

FUNCTIONAL DESCRIPTION

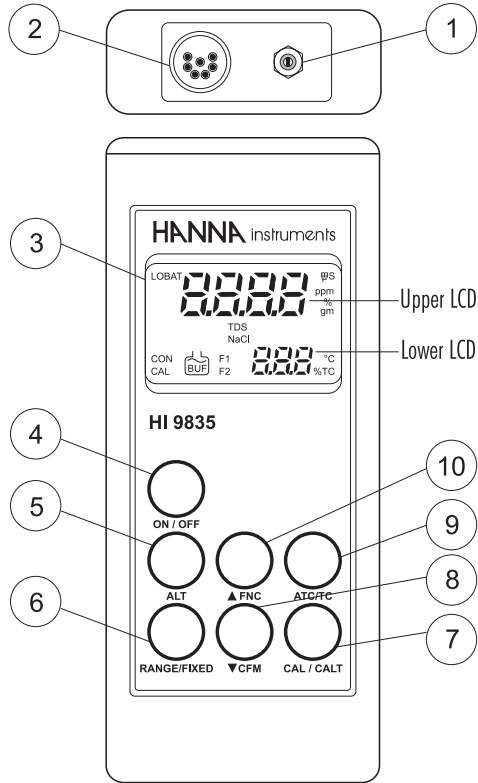

- 1) Power adapter socket
- 2) Probe Connector
- 3) Liquid Crystal Display (LCD)
- 4) ON/OFF key, to turn the meter on and off
- 5) ALT key, to alternate key function
- 6) RANGE / FIXED key, to select measurement range or (with ALT) to freeze the current range on the LCD
- 7) CAL / CALT key, to enter calibration mode
- 8) ▼CFM key, to move down or (with ALT) confirm values
- 9) ATC / TC key, to select temperature compensation mode or (with ALT) to view the temperature coefficient value
- 10) ▲FNC key, to move up or (with ALT) enter setup mode

SPECIFICATIONS

Range	EC	0.00 to 29.99 $\mu\text{S}/\text{cm}$
	(Autoranging)	30.0 to 299.9 $\mu\text{S}/\text{cm}$ 300 to 2999 $\mu\text{S}/\text{cm}$ 3.00 to 29.99 mS/cm 30.0 to 200.0 mS/cm Up to 500.0 mS/cm actual ^(*) Conductivity
	TDS	0.00 to 14.99 ppm (Autoranging) 15.0 to 149.9 ppm 150 to 1499 ppm 1.50 to 14.99 g/L 15.0 to 100.0 g/L Up to 400.0 g/L actual ^(*) TDS (with 0.80 factor)
NaCl	Temp.	0.0 to 400.0 % 0.0 to 60.0 $^{\circ}\text{C}$
Resolution	EC	0.01 $\mu\text{S}/\text{cm}$ (from 0.00 to 29.99 $\mu\text{S}/\text{cm}$) 0.1 $\mu\text{S}/\text{cm}$ (from 30.0 to 299.9 $\mu\text{S}/\text{cm}$) 1 $\mu\text{S}/\text{cm}$ (from 300 to 2999 $\mu\text{S}/\text{cm}$) 0.01 mS/cm (from 3.00 to 29.99 mS/cm) 0.1 mS/cm (over 30.0 mS/cm)
	TDS	0.01 ppm (from 0.00 to 14.99 ppm) 0.1 ppm (from 15.0 to 149.9 ppm) 1 ppm (from 150 to 1499 ppm) 0.01 g/L (from 1.50 to 14.99 g/L) 0.1 g/L (over 15.0 g/L)
	NaCl	Temp.
Accuracy	EC	$\pm 1\%$ of reading \pm (0.05 $\mu\text{S}/\text{cm}$ or 1 digit, whichever greater)
	TDS	$\pm 1\%$ of reading \pm (0.03 ppm or 1 digit, whichever greater)
	NaCl	Temp.
Typical EMC Deviation	EC	$\pm 1\%$ of reading
	TDS	$\pm 1\%$ of reading
	NaCl	$\pm 1\%$ of reading
	Temp.	$\pm 0.1^{\circ}\text{C}$

^(*) Actual conductivity (or TDS) is the non-temperature compensated conductivity (or TDS) value of a solution.

EC Calibration	1 point with 6 memorized buffers 84, 1413, 5000, 12880, 80000, 111800 $\mu\text{S}/\text{cm}$
NaCl Calibration	1 point with HI 7037 buffer (optional)
Temperature Calibration	2 points at 0 and 50 $^{\circ}\text{C}$ (plus ± 1 $^{\circ}\text{C}$ adjustment)
Temperature Compensation	Automatic or Manual from 0 to 60 $^{\circ}\text{C}$ (can be disabled to measure actual conductivity)
Temperature Coefficient	0.00 to 6.00 $\%/^{\circ}\text{C}$ (for EC and TDS only) Default value is 1.90 $\%/^{\circ}\text{C}$
TDS Factor	0.40 to 0.80 (default value is 0.50)
Probe	HI 76309 4-ring probe, K=1 nominal and built-in temperature sensor (included)
Auto Off	After 5 minutes (can be disabled)
Power supply	4x1.5V AA alkaline type batteries (included), or 12 VDC adapter
Casing	IP 67
Environment	0 to 50 $^{\circ}\text{C}$; 100% RH
Dimensions	196 x 80 x 60 mm (7.7 x 3.1 x 2.4")
Weight	500 g (18 oz)

CONNECTIONS

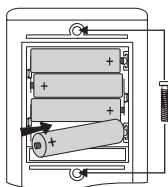

Remove the back cover, unwrap the batteries and install them while paying attention to the polarity. Replace the back cover.

Alternatively, connect the voltage adapter to the power socket.

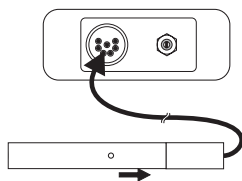

Connect the EC/TDS probe to the 7-pin connector located on the top of the instrument. Tighten the threaded ring.

Make sure the probe sleeve is properly inserted, as shown in the figure.

TAKING MEASUREMENTS



Press the ON/OFF key to turn the meter on.



Immerse the probe into the solution to be tested. The sleeve holes must be completely submerged. Tap the probe repeatedly to remove any air bubbles that may be trapped inside the sleeve.



If needed, press the RANGE key repeatedly until the desired range (EC, TDS, NaCl) is selected on the LCD.

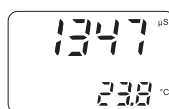

Allow for the reading to stabilize. The upper LCD displays the measure in the selected range while the temperature is displayed on the lower LCD.

Notes:

- I If the meter displays "----" the reading is out of range.
- II If the reading is unstable, the stability indicator "~" blinks.
- III The "gm" indication on the LCD means g/L.
- IV Make sure the meter is calibrated before taking measurements.
- V If measurements are taken successively in different samples, to have accurate readings it is recommended to rinse the probe thoroughly with deionized water before immersion in the samples.
- VI To maximize battery life, the meter is automatically switched off after 5 minutes of non-use. To reactivate the instrument press the ON/OFF key. This feature can be disabled by entering the setup mode and selecting the "AoF" item (see SETUP for details).
- VII TDS reading is obtained multiplying the EC reading by the TDS factor, which has a default value of 0.50. It is possible to change the TDS factor in the 0.40 to 0.80 range by entering the setup mode and selecting the "tdS" item (see SETUP for details).
- VIII When the use of an alternate function (FNC, CFM, GLP, FIXED, TC and CALT) is requested, press and hold the ALT key first and then the second key.

AUTORANGING

The EC and TDS scales are autoranging. The meter automatically sets the scale with the highest possible resolution.



By pressing ALT+FIXED, the autoranging feature is disabled and the current range is frozen on the LCD. "F1" symbol blinks on the LCD.

To restore the autoranging option press ALT+FIXED again.

Note: Autoranging is automatically restored if the RANGE key is pressed, if the setup or calibration modes are entered and if the meter is turned off and back on again.

TEMPERATURE COMPENSATION

Three options of compensating temperature are available:

Automatic (Atc): The probe has a built-in temperature sensor; the value of the temperature is used to automatically compensate the EC/TDS reading using 25°C as reference temperature. This is the default option.

Manual (Mtc): The temperature value, shown on the lower LCD, can be manually set by the user with the up and down arrow keys. The compensation is referenced at 25°C. The "°C" symbol blinks when this option is active.

No Compensation (notc): The temperature reading shown on the lower LCD is not taken into account. The reading displayed on the upper LCD is the actual EC or TDS value. The "°C" and "%TC" symbols blink when this option is active.



To select the desired option press the ATC key until the option is briefly displayed on the LCD.

Note: The default compensation mode is ATC.

If temperature compensation is active, measurements are compensated using a default temperature coefficient of 1.90%/°C.

It is possible to select a different temperature coefficient (TC) in the 0.00 to 6.00%/°C range by entering the setup mode and selecting the "tc" item (see SETUP for details).



The current temperature coefficient can be quickly viewed pressing ALT+TC. The value is briefly displayed on the lower LCD.

EC/TDS CALIBRATION

Calibration is a 1-point procedure. Selectable calibration points are: 0.0, 84.0µS, 1413µS, 5.00mS, 12.88mS, 80.0mS, 111.8mS.



To enter EC calibration select the EC range and press the CAL key.

Note: TDS reading is automatically derived from the EC reading and no specific calibration for TDS is needed. Pressing CAL while TDS range is selected has no effect.



Rinse the probe with some of the calibration solution or deionized water. Immerse the probe into the solution. The sleeve holes must be completely submerged. Tap the probe repeatedly to remove any air bubbles that may be trapped inside the sleeve.

For zero calibration, just leave the dry probe in air.



The indications "BUF" and "CAL" are displayed. The upper LCD shows the uncalibrated EC reading. The lower LCD shows the buffer value. The stability indicator "~" blinks.



Select the desired value with the ▲ and ▼ keys, if necessary.

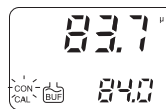

When the "~" symbol stops blinking, the reading is stable. The "CON" indication starts blinking on the LCD asking for confirmation.



Press ALT + CFM to confirm the calibration.

If everything is satisfactory, the meter displays the "Stor Good" message and returns to measurement mode.

Notes

- I If the uncalibrated reading is too far from the expected value, calibration is not recognized. The "CON" indication does not appear; the "~" and "BUF" symbols blink to signal wrong or contaminated calibration solution.
- II For best results choose an EC buffer value close to the sample to be measured.

- III In order to minimize any EMC interference, use plastic beakers.
- IV The meter uses 1.90%/°C compensation factor during calibration. If the setup item "tc" has been set to a different value, when exiting the calibration mode the value displayed on the upper LCD could be different from the nominal buffer value.
- V It is possible to set the cell constant value directly without following the calibration procedure. To set the cell constant enter the setup mode and select "CEL" (see SETUP for details).

NaCl CALIBRATION

Calibration is 1-point at 100.0% NaCl. Use the HI 7037 calibration solution (sea water solution) as a 100% NaCl standard solution.



To enter NaCl calibration select the NaCl range and press the CAL key.



Rinse the probe with some of the calibration solution or deionized water. Immerse the probe into HI 7037 solution. The sleeve holes must be completely submerged. Tap the probe repeatedly to remove any air bubbles that may be trapped inside the sleeve.



The indications "BUF" and "CAL" are displayed. The upper LCD shows the uncalibrated NaCl reading in percentage. The lower LCD shows "100".



When the "~" symbol stops blinking, the reading is stable. The "CON" indication starts blinking on the LCD asking for confirmation.



Press ALT + CFM to confirm the calibration.

If everything is satisfactory, the meter displays the "Stor Good" message and returns to measurement mode.

Note: If the uncalibrated reading is too far from the expected value, the calibration is not recognized. The "CON" indication does not appear; the "~" and "BUF" symbols blink to signal wrong or contaminated calibration solution.

Note: The meter uses 1.90%/°C compensation factor during calibration. If the setup item "tc" has been set to a different value, when exiting calibration mode the value displayed on the upper LCD could be different from the nominal calibration value.

TEMPERATURE CALIBRATION (for technical personnel only)

The calibration is 2 points at 0.0, 50.0°C.

- Immerse the probe in a 0°C temperature bath.
- Press ALT+CALT to enter temperature calibration mode.
- The lower LCD displays "0.0 °C"; "BUF" and "CAL" tags appear.
- When the reading is stable, "CON" symbol starts to blink.
- Press ALT+CFM to confirm. The lower LCD displays 50.0°C.
- Immerse the probe in a 50°C temperature bath.
- When the reading is stable, "CON" symbol starts to blink.
- Press ALT+CFM to confirm and return to normal operation.

TEMPERATURE ADJUSTMENT

The temperature reading can be manually fine-tuned by following this procedure:



Press ALT+CALT to enter the temperature calibration mode.



Press CAL to enter the temperature adjustment mode. The upper and lower LCD will display the current temperature reading.

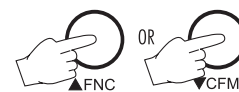

Adjust the temperature reading on the upper LCD using the arrow keys. The maximum adjustment is ±1°C around current reading.



Press ALT+CFM to confirm. The meter returns to measurement mode and displays the new temperature.

Note: Press ALT+CALT to escape without any changes.

Note: It is possible to enter the temperature adjustment mode only if the probe is connected.

CONDUCTIVITY VERSUS TEMPERATURE CHART

The conductivity of an aqueous solution is the measure of its ability to carry an electrical current by means of ionic motion.

The conductivity invariably increases with increasing temperature.

It is affected by the type and number of ions in the solution and by the viscosity of the solution itself. Both parameters are temperature dependent. The dependency of conductivity on temperature is expressed as a relative change per degree Celsius at a particular temperature, commonly as percent per $^{\circ}\text{C}$.

The following table lists the temperature dependence of the HANNA calibration buffers.

$^{\circ}\text{C}$	$^{\circ}\text{F}$	HI 7030 HI 8030 ($\mu\text{S/cm}$)	HI 7031 HI 8031 ($\mu\text{S/cm}$)	HI 7033 HI 8033 ($\mu\text{S/cm}$)	HI 7034 HI 8034 ($\mu\text{S/cm}$)	HI 7035 HI 8035 ($\mu\text{S/cm}$)	HI 7039 HI 8039 ($\mu\text{S/cm}$)
0	32	7150	776	64	48300	65400	2760
5	41	8220	896	65	53500	74100	3180
10	50	9330	1020	67	59600	83200	3615
15	59	10480	1147	68	65400	92500	4063
16	60.8	10720	1173	70	67200	94400	4155
17	62.6	10950	1199	71	68500	96300	4245
18	64.4	11190	1225	73	69800	98200	4337
19	66.2	11430	1251	74	71300	100200	4429
20	68	11670	1278	76	72400	102100	4523
21	69.8	11910	1305	78	74000	104000	4617
22	71.6	12150	1332	79	75200	105900	4711
23	73.4	12390	1359	81	76500	107900	4805
24	75.2	12640	1386	82	78300	109800	4902
25	77	12880	1413	84	80000	111800	5000
26	78.8	13130	1440	86	81300	113800	5096
27	80.6	13370	1467	87	83000	115700	5190
28	82.4	13620	1494	89	84900	117700	5286
29	84.2	13870	1521	90	86300	119700	5383
30	86	14120	1548	92	88200	121800	5479
31	87.8	14370	1575	94	90000	123900	5575

SETUP

Setup is used to view or change the instrument parameters.



To enter setup press ALT+FNC when the meter is in measurement mode.



"Set" is displayed on the upper LCD. The lower LCD displays the blinking code of the current setup item.



Select the desired setup item using the \blacktriangle or \blacktriangledown key.



Press ALT+CFM to confirm.

Note: If ALT+FNC are pressed before item confirmation, the meter will escape and return to measurement mode.

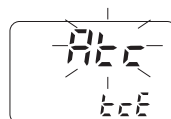

Once the desired setup item has been selected, its current value blinks (if it is a changeable parameter).

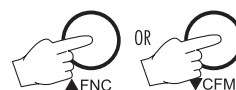

To change the value use the \blacktriangle or \blacktriangledown key.



Press ALT+CFM to confirm.

Note: Press ALT+FNC before confirmation to escape without changing the previously set value.

The following table lists the setup items, their valid range of values and the factory settings (default):

Item	Description	Valid values	Default
tc	Temp. compensation coeff.	0.00 to 6.00 %/□C	1.90
tcE	Temp. compensation mode	Atc, Mtc, notc	Atc
tdS	TDS factor	0.40 to 0.80	0.50
CEL	Cell constant (K)	0.500 to 1.700	1.000
Aof	Auto-Off enable	On, OFF	On
vEr	Firmware release		
Chr	Battery level test		

Notes

- I Once enabled, the Auto Off time is fixed at 5 minutes.
- II When the battery level test is selected (Chr), LCD will display the remaining percentage of battery charge. 100% means fully charged battery and 0% corresponds to the minimum battery level that allows the meter to operate.
- The battery charge level calculation is based on a typical alkaline battery discharge curve.
- If the meter is connected to an external power adapter and "Chr" is selected, the LCD will display "LINE".

BATTERY REPLACEMENT

When the batteries are inserted and no power adapter is connected, the meter can recognize the following battery charge levels:

- **Low battery** - "LOBAT" indication is displayed on the LCD. Backlight is automatically disabled and it is not possible to enable it until new batteries are inserted or an external power adapter is used. When "LOBAT" appears, batteries have typically 10% of their life left and the meter is still measuring properly.
- **Very weak battery** - The meter shuts off to avoid erroneous operations.

Note: If the meter is not powered for several minutes (e.g. in dead battery condition), the current date and time are lost.

Battery replacement must only take place in a non-hazardous area using 1.5V alkaline AA type batteries.

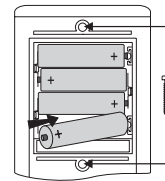

In order to replace run down batteries, simply remove the two screws on the rear cover of the instrument and replace the four 1.5V AA batteries with new ones, paying attention to the correct polarity.

New batteries allow 150 hours approx. of continuous use (with 2700 mA/h batteries and without backlight)

A 12VDC power adapter can also be used. It is recommended to use the Hanna voltage adapters that use the proper polarity configuration.

However, other adapters can be used. In this case, check the polarity of your adapter before connecting it to the meter.



PROBE MAINTENANCE

Rinse the probe with clean water after measurements. If a more thorough cleaning is required, remove the probe sleeve and clean the probe with a cloth or a nonabrasive detergent.

Make sure to reinsert the sleeve onto the probe properly and in the right direction.

After cleaning the probe, recalibrate the instrument.

ACCESSORIES

CONDUCTIVITY BUFFER SOLUTIONS

HI 70030P	12880 $\mu\text{S}/\text{cm}$ ($\mu\text{mho}/\text{cm}$), 20mL sachets (25 pcs.)
HI 7030L	12880 $\mu\text{S}/\text{cm}$ ($\mu\text{mho}/\text{cm}$), 460mL bottle
HI 7030M	12880 $\mu\text{S}/\text{cm}$ ($\mu\text{mho}/\text{cm}$), 230mL bottle
HI 70031P	1413 $\mu\text{S}/\text{cm}$ ($\mu\text{mho}/\text{cm}$), 20mL sachets (25 pcs.)
HI 7031L	1413 $\mu\text{S}/\text{cm}$ ($\mu\text{mho}/\text{cm}$), 460mL bottle
HI 7031M	1413 $\mu\text{S}/\text{cm}$ ($\mu\text{mho}/\text{cm}$), 230mL bottle
HI 70033P	84 $\mu\text{S}/\text{cm}$ ($\mu\text{mho}/\text{cm}$), 20mL sachets (25 pcs.)
HI 7033L	84 $\mu\text{S}/\text{cm}$ ($\mu\text{mho}/\text{cm}$), 460 mL bottle
HI 7033M	84 $\mu\text{S}/\text{cm}$ ($\mu\text{mho}/\text{cm}$), 230 mL bottle
HI 7034L	80000 $\mu\text{S}/\text{cm}$ ($\mu\text{mho}/\text{cm}$), 460mL bottle
HI 7034M	80000 $\mu\text{S}/\text{cm}$ ($\mu\text{mho}/\text{cm}$), 230mL bottle
HI 7035L	111800 $\mu\text{S}/\text{cm}$ ($\mu\text{mho}/\text{cm}$), 460mL bottle
HI 7035M	111800 $\mu\text{S}/\text{cm}$ ($\mu\text{mho}/\text{cm}$), 230mL bottle
HI 70039P	5000 $\mu\text{S}/\text{cm}$ ($\mu\text{mho}/\text{cm}$), 20mL sachets (25 pcs.)
HI 7039L	5000 $\mu\text{S}/\text{cm}$ ($\mu\text{mho}/\text{cm}$), 460mL bottle
HI 7039M	5000 $\mu\text{S}/\text{cm}$ ($\mu\text{mho}/\text{cm}$), 230mL bottle
HI 7037L	100% NaCl sea water standard solution, 460mL

CONDUCTIVITY BUFFER SOLUTIONS IN FDA APPROVED BOTTLES

HI 8030L	12880 $\mu\text{S}/\text{cm}$ ($\mu\text{mho}/\text{cm}$), 460 mL bottle
HI 8031L	1413 $\mu\text{S}/\text{cm}$ ($\mu\text{mho}/\text{cm}$), 460 mL bottle
HI 8033L	84 $\mu\text{S}/\text{cm}$ ($\mu\text{mho}/\text{cm}$), 460 mL bottle
HI 8034L	80000 $\mu\text{S}/\text{cm}$ ($\mu\text{mho}/\text{cm}$), 460 mL bottle
HI 8035L	111800 $\mu\text{S}/\text{cm}$ ($\mu\text{mho}/\text{cm}$), 460 mL bottle
HI 8039L	5000 $\mu\text{S}/\text{cm}$ ($\mu\text{mho}/\text{cm}$), 460 mL bottle

PROBE CLEANING SOLUTIONS

HI 7061M	General Cleaning Sol., 230 mL bottle
HI 7061L	General Cleaning Sol., 460 mL bottle

PROBE CLEANING SOLUTIONS IN FDA APPROVED BOTTLES

HI 8061M	General Cleaning Sol., 230 mL bottle
HI 8061L	General Cleaning Sol., 460 mL bottle

OTHER ACCESSORIES

HI 76309	stainless steel 4-ring conductivity/TDS probe with temperature sensor and 1m (3.3') cable.
HI 76310	platinum 4-ring conductivity/TDS probe with temperature sensor and 1m (3.3') cable.
HI 710005	12VDC voltage adapter (US plug)
HI 710006	12VDC voltage adapter (European plug)
HI 710012	12VDC voltage adapter (UK plug)
HI 710013	12VDC voltage adapter (S. Africa plug)
HI 710014	12VDC voltage adapter (Australian plug)
HI 740027	1.5V AA batteries (4 pcs)
HI 740036	100mL plastic beaker (6 pcs)
HI 740034	Cap for 100mL beakers (6 pcs)
HI 76405	Electrode holder

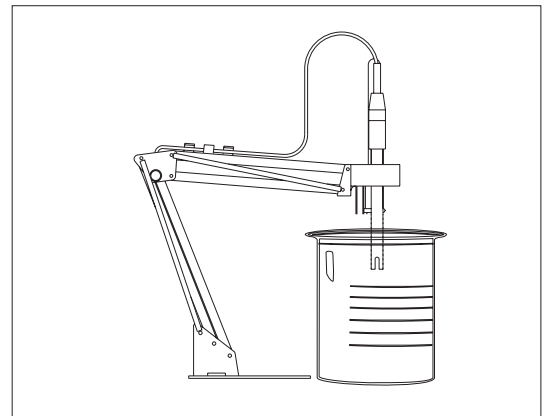

WARRANTY

All Hanna Instruments meters are warranted for two years against defects in workmanship and materials when used for their intended purpose and maintained according to instructions. The electrodes and the probes are warranted for a period of six months. This warranty is limited to repair or replacement free of charge.

Damages due to accident, misuse, tampering or lack of prescribed maintenance are not covered.

If service is required, contact the dealer from whom you purchased the instrument. If under warranty, report the model number, date of purchase, serial number and the nature of the failure. If the repair is not covered by the warranty, you will be notified of the charges incurred. If the instrument is to be returned to Hanna Instruments, first obtain a Returned Goods Authorization number from the Customer Service department and then send it with shipping costs prepaid. When shipping any instrument, make sure it is properly packaged for complete protection.

To validate your warranty, fill out and return the enclosed warranty card within 14 days from the date of purchase.

Hanna Instruments reserves the right to modify the design, construction and appearance of its products without advance notice.

CE DECLARATION OF CONFORMITY



DECLARATION OF CONFORMITY

We

Hanna Instruments Italia Srl
via E. Fermi, 10
35030 Sarmeola di Rubano - PD
ITALY

herewith certify that the EC/TDS meter

HI 9835

has been tested and found to be in compliance with EMC Directive 89/336/EEC and Low Voltage Directive 73/23/EEC according to the following applicable normatives:

EN 50082-1: Electromagnetic Compatibility - Generic Immunity Standard
IEC 801-2 Electrostatic Discharge
IEC 801-3 RF Radiated
IEC 801-4 Fast Transient

EN 50081-1: Electromagnetic Compatibility - Generic Emission Standard
EN 55022 Radiated, Class B

EN61010-1: Safety requirements for electrical equipment for measurement, control and laboratory use

Date of Issue: 24-1-2000

P. Cesa - Technical Director
On behalf of
Hanna Instruments S.r.l.

Recommendations for Users

Before using this product, make sure that it is entirely suitable for the environment in which it is used.

Operation of this instrument in residential area could cause unacceptable interference to radio and TV equipment, requiring the operator to take all necessary steps to correct interference.

The metal bands of the probe are sensitive to electrostatic discharges. Avoid touching these metal bands at all times.

To maintain the EMC performance of this equipment the recommended cables must be used.

Any variation introduced by the user to the supplied equipment may degrade the instruments EMC performance.

To avoid electrical shock, do not use this instrument when voltage at the measurement surface exceeds 24VAC or 60 VDC.

To avoid damages or burns, do not perform any measurement in microwave ovens.

HANNA LITERATURE

Hanna publishes a wide range of catalogs and handbooks for an equally wide range of applications. The reference literature currently covers areas such as:

- **Water Treatment**
- **Process**
- **Swimming Pools**
- **Agriculture**
- **Food**
- **Laboratory**
- **Thermometry**

and many others. New reference material is constantly being added to the library.

For these and others catalogs, handbooks and leaflets, contact your dealer or the Hanna Customer Service Center nearest to you. To find the Hanna Office in your vicinity, check our home page at www.hannainst.com

HANNA
10/00
83587



<http://www.hannainst.com>